

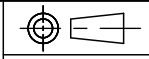

Surface vitrée: 122.424 po<sup>2</sup>

<b>FABRICANT DE POÊLES INTERNATIONAL INC.</b> 250, rue de Copenhague, Saint-Augustin-de-Desmaures (Québec) G3A 2H3 Tél : ( 418 ) 878-3040 Fax : ( 418 ) 878-3001 <a href="http://www.sbi-international.com">www.sbi-international.com</a>		TOLÉRANCES FRACTION : ± 1/32" .XX : ±.020" .XXX : ±.010" ANGLES : ±0.5°	 THESE ALLOWANCES ARE NOT CUMULATIVE
NOM DE LA PIÈCE / PART NAME <b>VUES OB01151 /</b> <b>OB01151 VIEWS</b>		RÉVISIONS / REVISIONS 	
CONCEPTEUR P. Bégin	DESSINATEUR J-P Alain	PAGE 3 de 5	DESSIN / DRAWING NBR OB01151-WEB



SECTION A-A

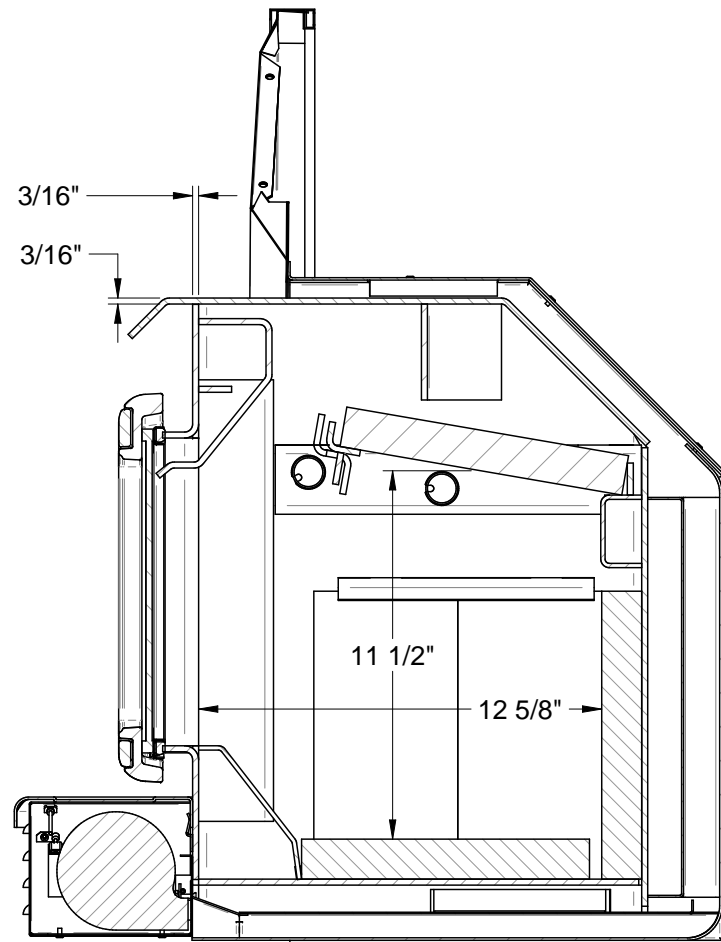
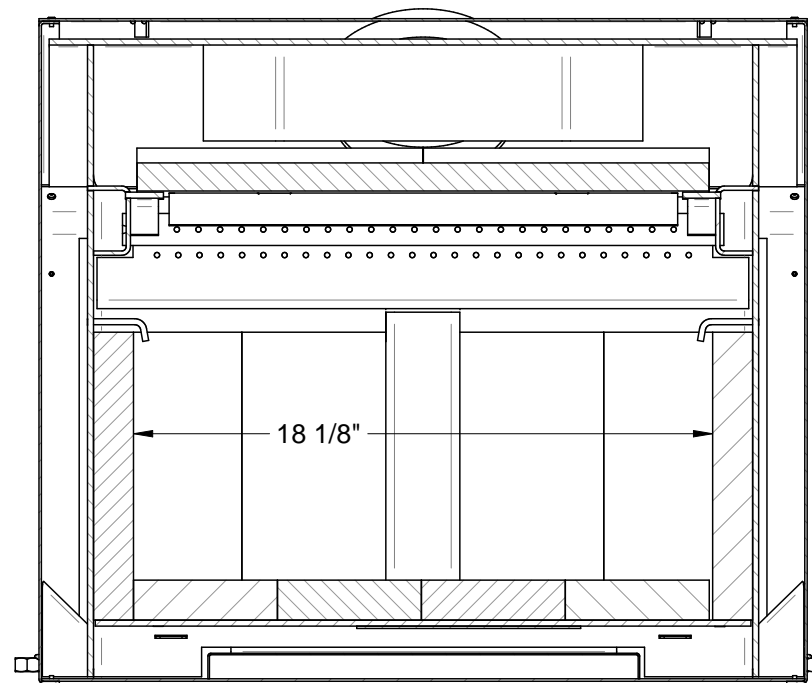

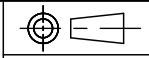

SECTION C-C

Volume de la chambre à combustion: 2631.523 po<sup>3</sup>

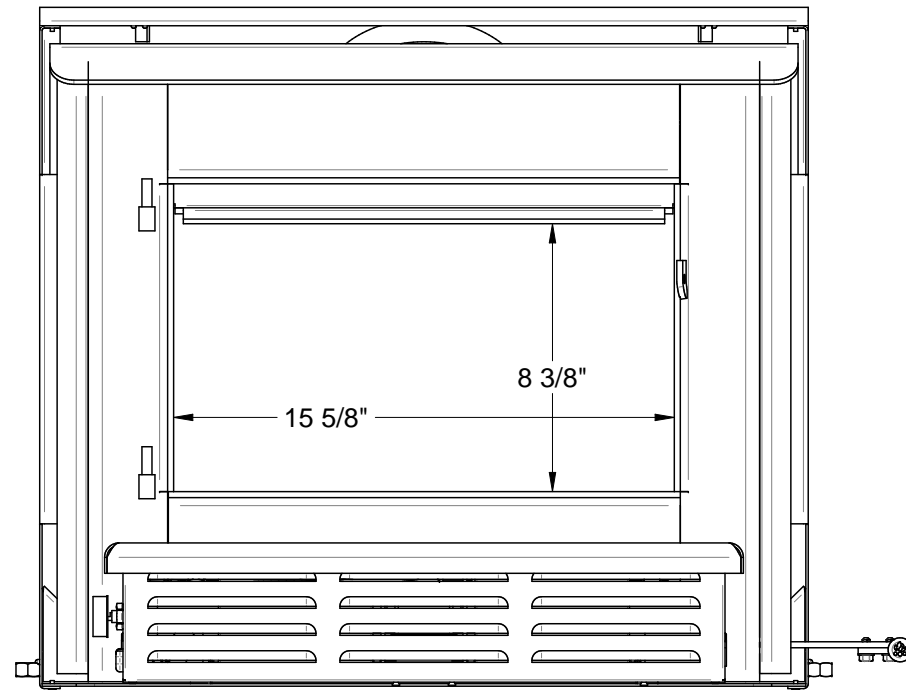
<b>FABRICANT DE POÊLES INTERNATIONAL INC.</b> 250, rue de Copenhague, Saint-Augustin-de-Desmaures (Québec) G3A 2H3 Tél : ( 418 ) 878-3040 Fax : ( 418 ) 878-3001 <a href="http://www.sbi-international.com">www.sbi-international.com</a>		<b>TOLÉRANCES</b> FRACTION : ± 1/32" .XX : ±.020" .XXX : ±.010" ANGLES : ±0.5°	 THESE ALLOWANCES ARE NOT CUMULATIVE
NOM DE LA PIÈCE / PART NAME <b>VUES OB01151 /</b> <b>OB01151 VIEWS</b>		RÉVISIONS / REVISIONS 	
CONCEPTEUR P. Bégin	DESSINATEUR J-P Alain	PAGE 4 de 5	DESSIN / DRAWING NBR OB01151-WEB

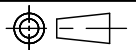

<b>FABRICANT DE POÊLES INTERNATIONAL INC.</b> 250, rue de Copenhague, Saint-Augustin-de-Desmaures (Québec) G3A 2H3 Tél : ( 418 ) 878-3040 Fax : ( 418 ) 878-3001 <a href="http://www.sbi-international.com">www.sbi-international.com</a>		<b>TOLÉRANCES</b> FRACTION : ± 1/32" .XX : ±.020" .XXX : ±.010" ANGLES : ±0.5°	 THESE ALLOWANCES ARE NOT CUMULATIVE
<b>NOM DE LA PIÈCE / PART NAME</b> <b>VUES OB01151 /</b> <b>OB01151 VIEWS</b>		<b>RÉVISIONS / REVISIONS</b> 	
<b>CONCEPTEUR</b> P. Bégin	<b>DESSINATEUR</b> J-P Alain	<b>PAGE</b> 5 de 5	<b>DESSIN / DRAWING NBR</b> OB01151-WEB