

# Milan FPI Dimensions

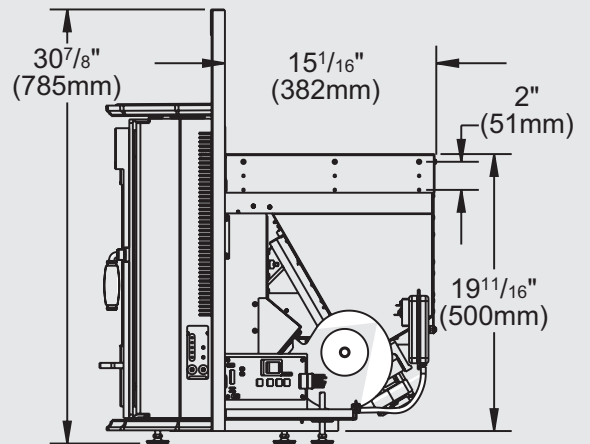
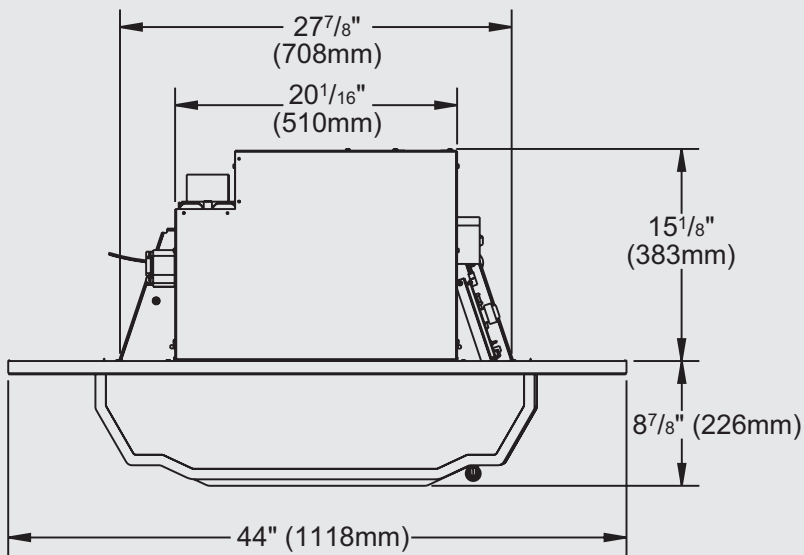
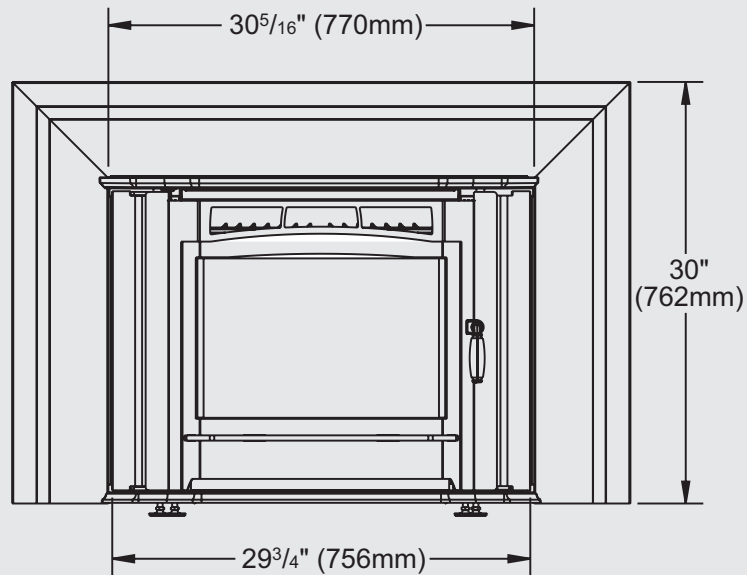

## Min. Clearance to Combustibles

## Milan

A - center of unit to side wall	24"
B - Bottom of unit to bottom of 12" mantle	36"
C - bottom to max. $\frac{3}{4}$ " combustible facing	0"
D - side of unit to side facing ( $\frac{3}{4}$ protrusion)	0"
E - front of door to edge of floor protection	16" (18" CDN)
F - side of unit to side of floor protection	6" (8" CDN)

